

Half Round Trim & Ex. Jambs



Date _____ Job Name _____ Co. _____
 Name _____ Contact _____ Phone _____
 _____ Fax _____

424 S. Washington St.
 Suite B. Kimberly, WI 54136
 Phone: 920/788-9322
 Fax: 920/788-3086
 www.elipticon.com

Quote Purchase Order _____

Fill in: A & B dimensions. A – base dimension, B – height of window.

Standard reveal 1/4" on all casings unless specified.

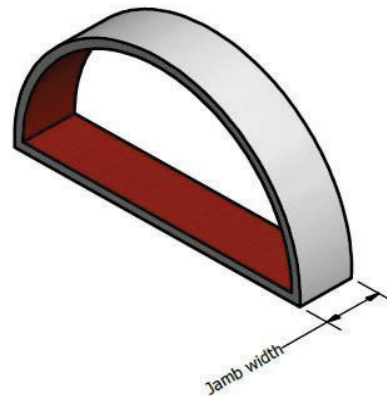
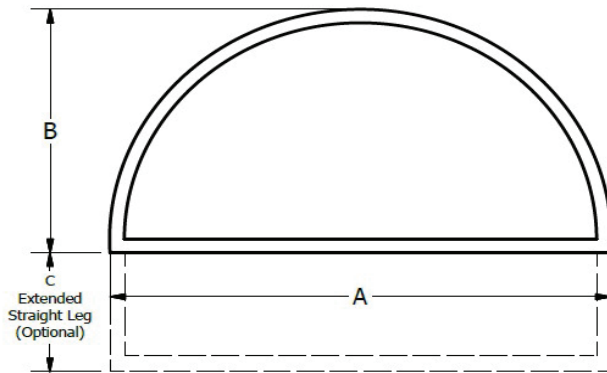

Dimension reference (check one)

- Outside to outside
Jamb thickness _____
- Inside, jamb to jamb

A Dimension: _____

B Dimension: _____

C Extended leg length: _____
 (additional charge)

Casing

Profile _____

Wood Species _____

Quantity _____

Extension Jamb

Thickness _____

Width _____

Quantity _____

Rosettes needed. Description _____

Straight moldings needed: length _____ quantity _____

length _____ quantity _____

length _____ quantity _____

Other notes: _____

